

Dry screening without plugging

Flexible screens that periodically receive an impact at a specific point on the screen do not become plugged at that point. Our system applies this principle to the entire screen, keeping it permanently clean.



NEW PRODUCTION LINE

Flexible, moving Inaprene[®] polyurethane striking arms + Ine-Flow[®] polyurethane screens for high performance screening

- Easy to fit to conventional screeners.
- Problem-free grading of aggregates with 40% clay fines and 12% humidity employing very small mesh sizes (4x4 mm or less).
- Mesh openings are always kept clear. No filler adherence so that production capacity is the maximum for each mesh opening.
- For all types of materials that are difficult to screen.
- Our system enables problem-free use of small mesh sizes to allow recovery of the smallest aggregates that previously had to be discarded.
- The striking arms and Ine-Flow[®] screens made of Inaprene[®] polyurethane are long lasting and ensure high performance and reliability.

The most effective solution for dry screening

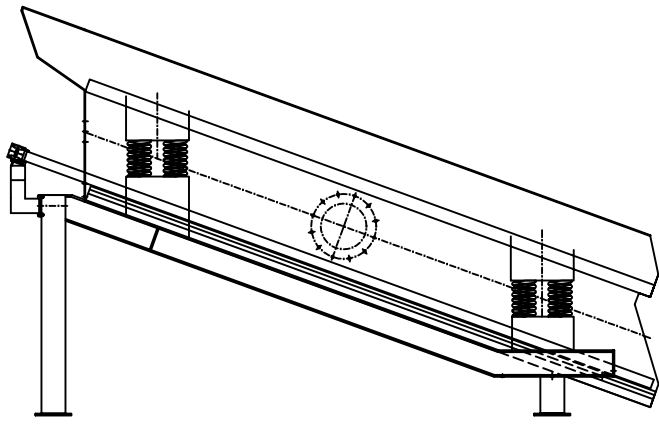

Screen with one striking arm

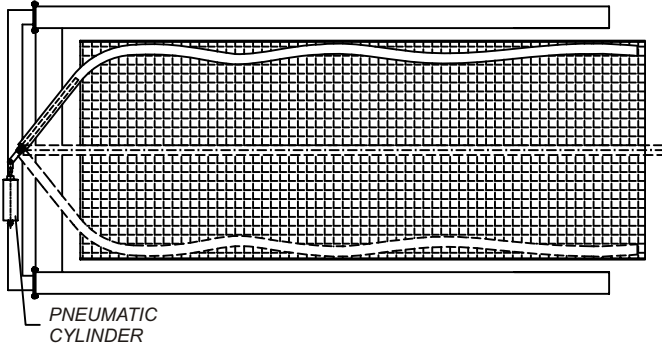

Screen with two striking arms

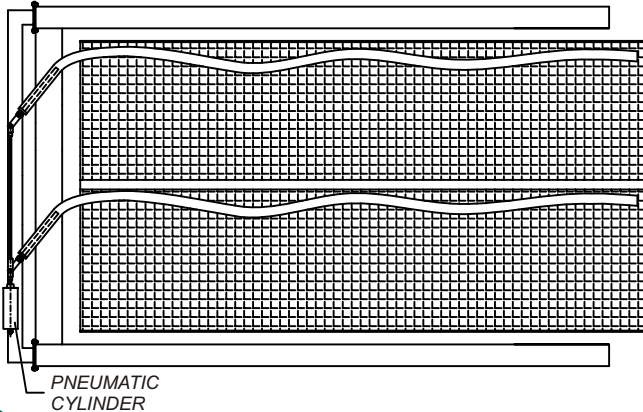

DESCRIPTION

Depending on the width of the screener, one or several flexible Inaprene® polyurethane arms with a rigid steel end insert move laterally between the walls and above the screen.

The vibration of the screener causes a snaking movement in each arm with a jolting effect that cause it to strike the screen in all of its areas, preventing plugging.

A two-way pneumatic cylinder transmits a reciprocating movement to the flexible arms.

Best performance is achieved with Ine-Flow® screens made in Inaprene® polyurethane to take advantage of the non-adhering nature of the material together with the vibration of its cables that stops aggregates from adhering to the screen.



Close-up of propulsion mechanism.

MOUNTING

The pneumatic cylinder and flexible arms are mounted on a square 120x120x6 mm tube that should be welded to other arms and these in turn will be screwed to the static frame of the screener. Any section type can be used: square, rectangular, U-shaped, etc. or even reinforced plates, given that the vibrations transmitted to the beam are very much damped. Section size will be determined depending on the possibilities of each individual installation.

The pneumatic components for high-precision control of the movement of the flexible arms as they sweep across the screens are housed in a cabinet.

Air pressure of 4 to 5 kg/cm² is sufficient and consumption is the minimum required to drive the cylinder in a reciprocating movement, at approximately one to three minute intervals.

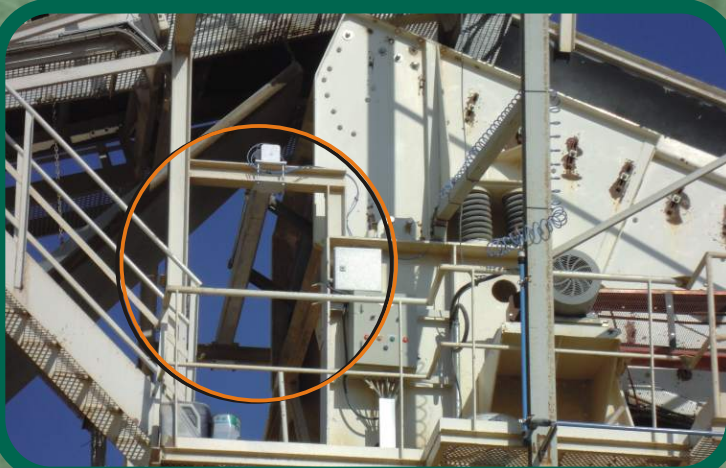

Close-up of coupling to a screener